

# Epoch Design, LLC

Congratulations on the purchase of your Chelan Solid Hardwood Bunk Bed. This bed has been crafted to the highest standards of quality and safety and will give you many years of enjoyment and practical use. Your Solid Hardwood Bunk Bed can be separated into two individual twin beds when the need arises for separate sleeping configurations.

Since this bed is a natural wood product there will be variations in color and grain, and minor checking may occur. This is normal and does not compromise the integrity of your bed. In fact, variation in character of solid hardwood is integral to the beauty and appeal of hardwood furniture, and distinguishes it from prefabricated, synthetic and composite materials.

Several basic safety considerations must be adhered to when using this bunk bed.

## **TO HELP PREVENT serious or fatal injury from entrapment or falls:**

- Never allow a child under 6 years on upper bunk.***
- ✓ ***Use correct size mattress (standard twin 38"X74").***
- ✓ ***Ensure thickness of mattress does not exceed 9 inches.***
- ✓ ***Mattress must be at least 5 inches below upper edge of guardrails.***
- ✓ ***Use guardrails on both sides of upper bunk.***
- ✓ ***Prohibit horseplay on or under bed(s).***
- ✓ ***Prohibit more than one person on upper bunk.***
- ✓ ***Use the ladder for entering and leaving upper bunk.***
- ✓ ***If the bunk will be placed next to a wall, the guardrail that runs the full length of the bed should be placed against the wall to prevent entrapment between the bed and the wall.***
- ✓

On this insert you will find a list of the hardware and bunk bed parts necessary for assembly, as well as detailed instructions. Assembly is quite simple and requires only a flat head screwdriver and a phillips head screwdriver. The use of a power drill with phillips head attachment is helpful but not necessary. Assembly will be most easily accomplished if you take the time to carefully sort the hardware and familiarize yourself with the function of each piece.

If you need assistance with assembly, part replacement or any other matter, contact the toll-free Epoch Design Service Center from anywhere in the Continental United States, Monday through Friday, 10AM - 5PM Pacific Standard Time at 1-800-589-7990. You may also fax your request or comments to 425-424-8751 and a service representative will respond.

**Thank you and Enjoy**

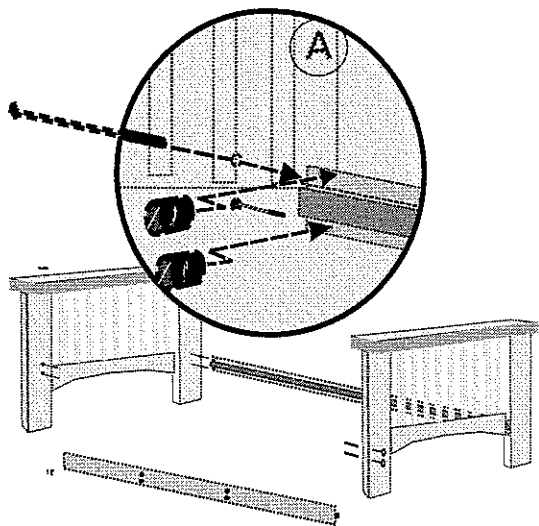

1) To assemble upper bunk, attach short end boards to upper bunk side rails. The side rails used on upper bunk have predrilled holes for safety rail attachment. Insert barrel nuts into side rails. Insert 100mm bolts through endboards and into barrel nuts (See Diagram A).

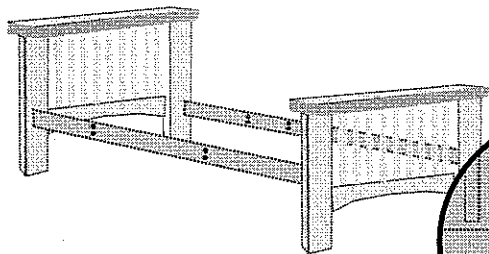

2) Tighten 100mm bolts with hex key provided (See Diagram B).

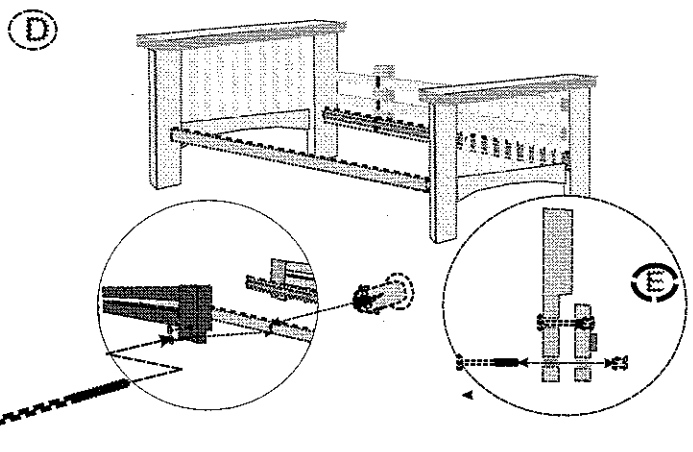
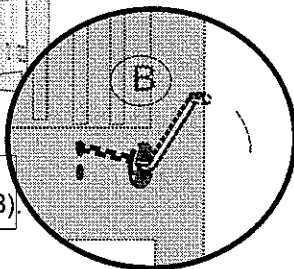

4) Attach both the long and the short safety rails to the side rails of the upper bunk using eight 50 mm bolts and eight propel nuts (See Diagrams D & E). The long rail will be on the side of the bunk which is opposite the ladder. The short rail will be used on the side of the bunk accessed by the ladder..

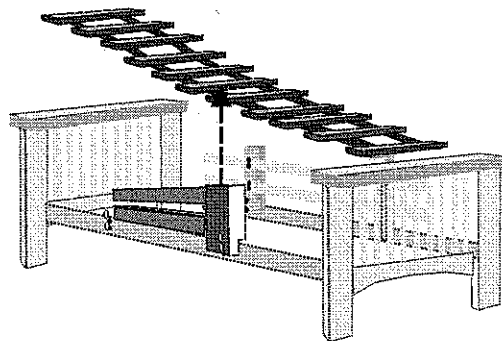

5) Unroll slat bundle (strap side down) onto side rail ledges from end to end..

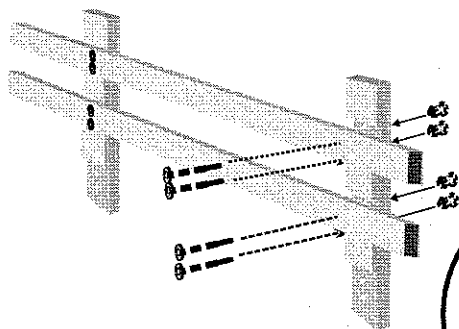

3) Attach the two long safety rails to the unassembled upright supports using eight 50 mm bolts and eight propel nuts. Tighten with hex key (See Diagrams C).

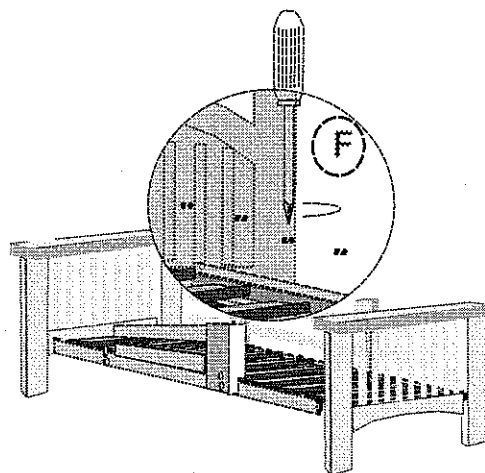
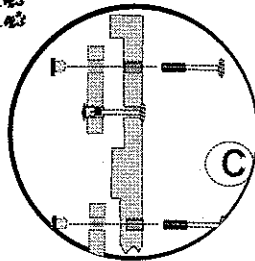

6) Attach slats to side rail ledge with slat screws using a phillips head screwdriver (See Diagram F). A power screwdriver comes in handy here.

Have a question??.. need a part ASAP??.. 1-800-589-7990

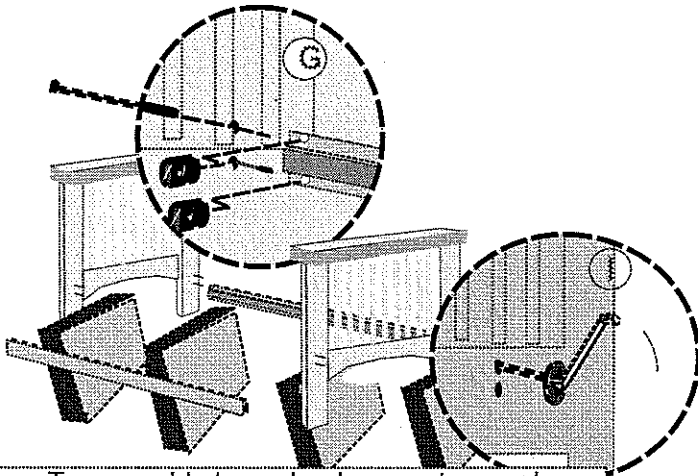

7) To assemble lower bunk, repeat procedure used for upper bunk using taller end boards. (See Diagram G). Tighten 100mm bolts to barrel nuts with hex key (See Diagram I).

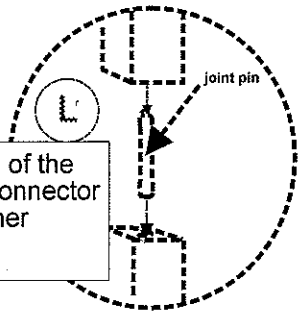

10) Place the upper bunk on top of the lower bunk, inserting bunk connector pin into each of the four corner posts (See Diagram L).

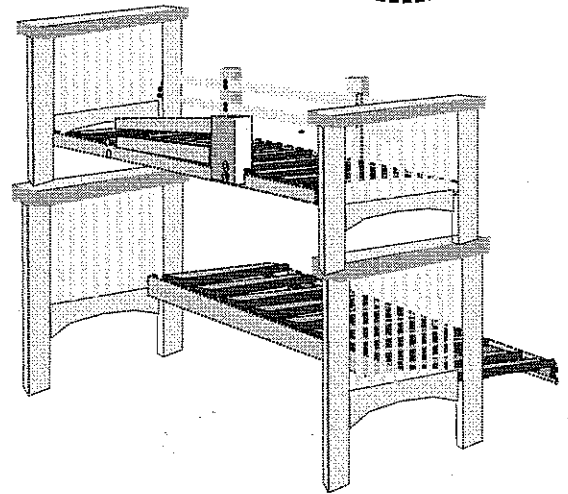

J

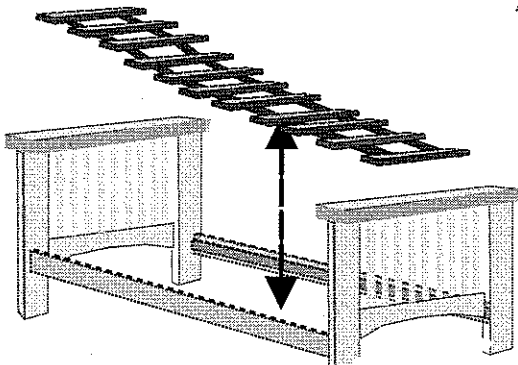

8) Unroll slat bundle (strap side down) onto ledges of side rails (See Diagram J).

11) Attach ladder hook to the top back sides of ladder using ladder hook screws (See Diagram M).

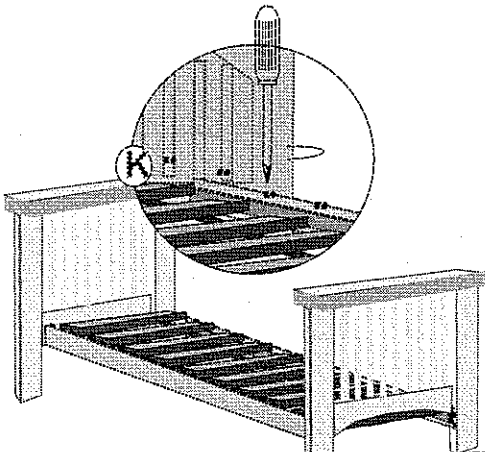

9) Attach slat bundle to side rail ledges with slat screws using a phillips head screwdriver. A power screwdriver comes in handy here (See Diagram K).

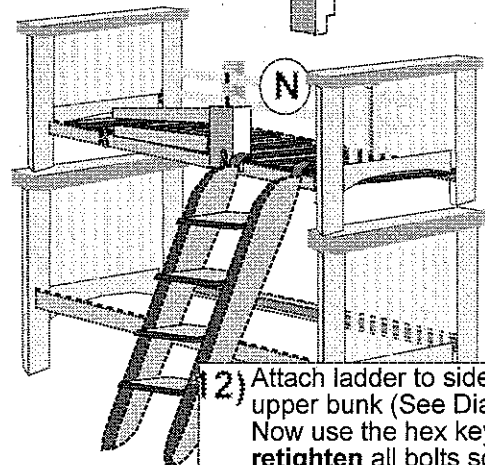









12) Attach ladder to side rail of upper bunk (See Diagram N). Now use the hex key to retighten all bolts so that bunk bed assembly is rigid. It may be necessary to retighten bunk after wood has acclimated to your weather region.







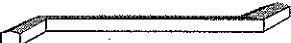

# Chelan hardware list

use

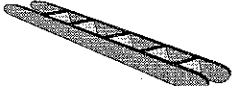
quantity

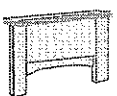
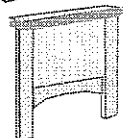
16		100 mm bolt	Used to connect headboard & footboard to side rails
16		50 mm bolt	Used to attach safety rail to bunk
16		barrel nut	Used to secure bolts
16		propel nuts	Used to attach safety rail to side rail with 50 mm bolt
4		upper/lower bunk connector pin	Used to connect lower bunk to upper bunk
64		slat screw	Used to secure slats to rail
4		ladder hook screw	Used to attach hooks to ladder
2		ladder hook	Used to secure ladder to bed
1		hex key	Tool used to tighten bolt hardware

## bunk bed parts

2		Side rails which connect end boards on the lower bunk
2		Side rails which connect end boards on the upper bunk
1		Ladder which attaches to upper side rail for entry to upper bunk
2		Slat bundles which rest on side rails, strap side down, and support mattresses
2		Shorter end boards for use on the upper bunk
2		Taller end boards for use on the lower bunk
2		Long safety rails for attachment to upright support on upper bunk (wall side of bunk)
2		Upright support for attachment of long safety rails to upper bunk
1		Short safety rail for attachment to ladder access side of bunk
4		Ornamental wood caps for use on headboards when bunks are separate

Have a question??.. need a part ASAP??..1-800-589-7990